

TREXiA ES

Diesel Counterbalance
6 Wheel Pneumatic Tyres • 7.0 tonnes

FD70N

Exceptional performance... Exceptional economy

Built to combine exceptional lifting performance with money-saving fuel economy, the TREXiA 7.0 tonne diesel counterbalance is the ultimate forklift for demanding applications.

At its heart is a turbo-charged, Stage IIIB compliant, four cylinder engine that delivers exceptionally high power while actually reducing particulates emissions and fuel consumption. This can be further enhanced via a fuel-saver mode that achieves a further 14% increase in fuel efficiency by decreasing the acceleration curve – without any decrease in top travel speed.

Highly intuitive to drive, TREXiA provides the precise, quiet and effortless performance that enables operators to maximise their potential, whatever the working environment. Year in, year out.

In short, it's everything you'd expect from a Mitsubishi forklift... and then some.

Frame and body

- **Rugged design** features heavy-duty frame – reinforced to minimise stress points during heavy lifting operations.
- **Low counterweight design** provides optimum visibility during reverse operations.
- **Fully enclosed wheel arches** protect vital components from dust – minimising risk of premature failure and minimising noise.

Mast and fork assembly

- **Robust mast construction** easily accommodates the stresses imposed by wide loads and offers exceptional visibility – protecting loads and colleagues.



Diesel Counterbalance 6 Wheel Pneumatic Tyres • 7.0 tonnes

Characteristics			
1.1	Manufacturer (abbreviation)		Mitsubishi
1.2	Manufacturer's model designation		FD70N
1.3	Power source: (battery, diesel, LP gas, petrol)		Diesel
1.4	Operator type: pedestrian, (operator)-standing, -seated		Seated
1.5	Load capacity	Q (kg)	7000
1.6	At load centre	c (mm)	600
1.8	Load distance	x (mm)	585
1.9	Wheelbase	y (mm)	2300
Weight			
2.1	Truck weight, without load / including battery (simplex mast, lowest lift height)	kg	9420
2.2	Axle loading with maximum load, front/rear (simplex mast, lowest lift height)	kg	14800 / 1620
2.3	Axle loading without load, front/rear (simplex mast, lowest lift height)	kg	4190 / 5230
Wheels, Drive Train			
3.1	Tyre type: V=solid, L=pneumatic, SE=solid pneumatic - front/rear		L
3.2	Tyre dimensions, front		8.25×15-12PR
3.3	Tyre dimensions, rear		8.25×15-12PR
3.5	Number of wheels, front/rear (x=driven)		4X / 2
3.6	Track width (centre of tyres), front	b10 (mm)	1650
3.7	Track width (centre of tyres), rear	b11 (mm)	1650
Dimensions			
4.1	Mast tilt, forwards/backwards	∂/B °	6 / 12
4.2	Height with mast lowered (see tables)	h1 (mm)	2720
4.3	Free lift (see tables)	h2 (mm)	200
4.4	Lift height (see tables)	h3 (mm)	3300
4.5	Overall height with mast raised	h4 (mm)	4580
4.7	Height to top of overhead guard	h6 (mm)	2610
4.8	Seat height	h7 (mm)	1592
4.12	Tow coupling height	h10 (mm)	485
4.19	Overall length	l1 (mm)	4800
4.20	Length to fork face (includes fork thickness)	l2 (mm)	3580
4.21	Overall width	b1 (mm)	2170
4.22	Fork dimensions (thickness, width, length)	s / e / l (mm)	60 / 150 / 1220
4.23	Fork carriage to DIN 15 173 A/B/no		IV A/no
4.24	Fork carriage width	b3 (mm)	1700
4.31	Ground clearance under mast, with load	m1 (mm)	170
4.32	Ground clearance at centre of wheelbase, with load (forks lowered)	m2 (mm)	263
4.33	Working aisle width with 1000 x1200 mm pallets, crosswise	Ast (mm)	5095
4.34	Working aisle width with 800 x1200 mm pallets, crosswise	Ast (mm)	5295
4.35	Turning circle radius	Wa (mm)	3310
4.36	Minimum distance between centres of rotation	b13 (mm)	1260
Performance			
5.1	Travel speed, with/without load	(mm)	24.0 / 27.0
5.2	Lifting speed, with/without load	m/s	0.45 / 0.49
5.3	Lowering speed, with/without load	m/s	0.55 / 0.50
5.5	Rated drawbar pull, with/without load	N	52900 / 27200
5.7	Gradeability, with/without load	%	35 / 27
5.10	Service brakes (mechanical/hydraulic/electric/pneumatic)		hydraulic
IC Engine			
7.1	Manufacturer / Type		Perkins 854E
7.2	Rated output B to ISO 1585	kW	68
7.3	Rated speed to DIN 70 020	rpm	2300
7.4	Number of cylinders / cubic capacity	cm ³	4 / 3400
7.5*	Fuel consumption according to VDI cycle	l/h / kg/h	-
Miscellaneous			
8.1	Type of drive control		Torque converter
8.2	Maximum operating pressure for attachments	bar	191
8.3	Oil flow for attachments	l/min	-
8.4	Noise level, mean value at operator's ear	dB(A)	83.4
8.5	Towing coupling design / DIN type, ref.		Pin

Continuing improvement may lead to changes in these specifications.

* Fuel consumption data available upon request.

FD70N Model

Mast Performance and Capacity

Mast type		h3 mm	h1 mm	h4 mm	h2/h5 mm	Tilt deg	Q @ c=600mm kg
Simplex	4V70C30	3,060	2,570	4,277	200	6°F/12°B	7000
	4V70C33	3,360	2,720	4,577	200	6°F/12°B	7000
	4V70C35	3,560	2,820	4,777	200	6°F/12°B	7000
	4V70C37	3,760	2,920	4,977	200	6°F/12°B	7000
	4V70C40	4,060	3,070	5,277	200	6°F/12°B	7000
	4V70C45	4,560	3,320	5,777	200	6°F/12°B	7000
	4V70C50	5,060	3,670	6,277	200	6°F/12°B	7000
	4V70C55	5,560	3,920	6,777	200	6°F/6°B	6700
4V70C60	6,060	4,170	7,277	200	6°F/6°B	6400	
Triplex	4M70C40	4,060	2,470	5,277	1,253	6°F/6°B	6200
	4M70C45	4,570	2,640	5,787	1,423	6°F/6°B	6200
	4M70C50	5,060	2,820	6,277	1,603	6°F/6°B	6200
	4M70C55	5,560	3,070	6,777	1,853	6°F/6°B	6000
	4M70C60	6,070	3,240	7,287	2,023	6°F/6°B	5700

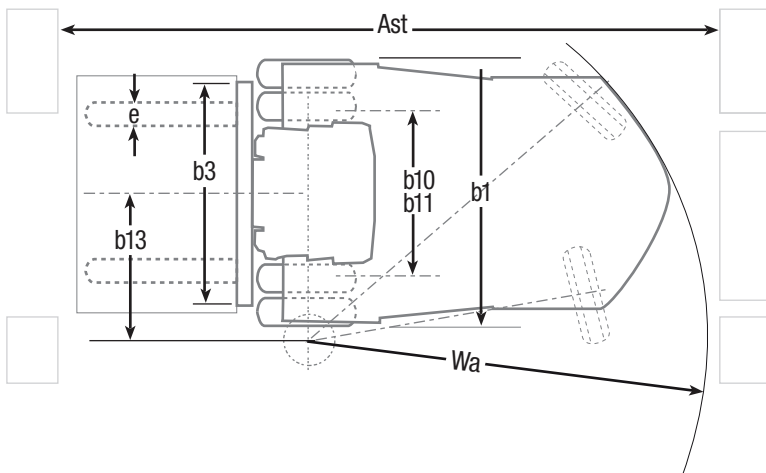
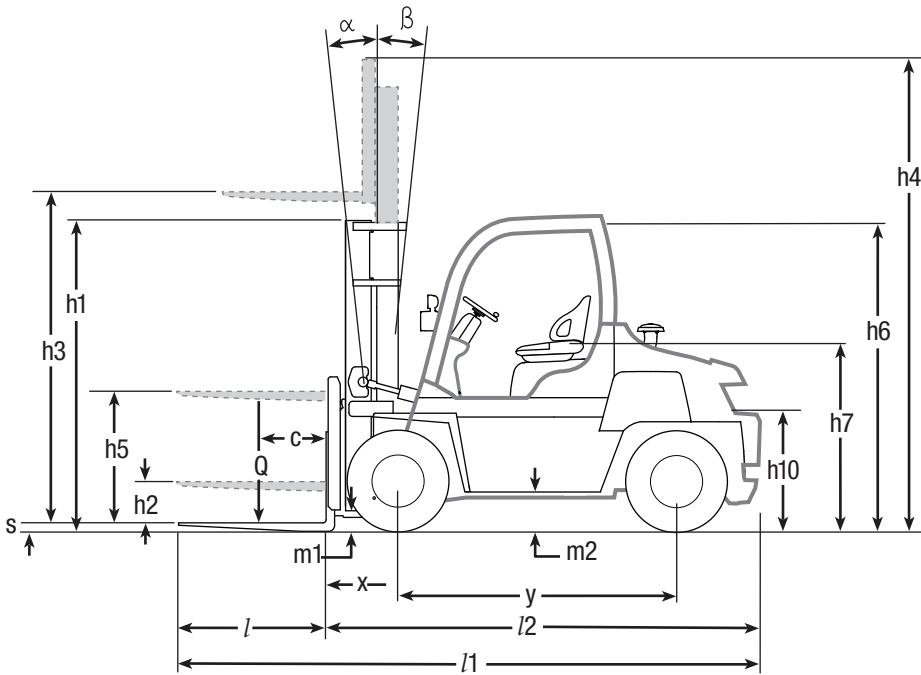

Full-suspension vinyl seat



Sealed tilt cylinders



Heavy duty steer axle



Spacious operator compartment



RapidAccess features



Premium LED/LCD information panel



Responsive hydrostatic steering



Easy access step and grab handle

Drive

- **Clean and lean running engine** *exceeds Tier IV final emission requirements, for significantly reduced levels of particulate matter (soot) during operation while enhancing overall performance and reliability.*
- **Turbocharged four cylinder engine** *delivers the power of a 5.0L engine in a 3.4L package for reduced fuel consumption and increased efficiency.*
- **Precise torque converter** *together with compact turbocharger, allows delivers controlled yet powerful acceleration while driving up ramps and moving heavy pallets outdoors.*
- **EcoDrive fuel-saving mode** *enables operators to achieve 14% greater fuel efficiency during acceleration – without reducing the truck's top travel speed. (Optional.)*

Steering

- **Responsive hydrostatic steering** *provides precise handling with low driver effort.*

Brakes

- **Vacuum-boosted duo-servo auto-style brakes** *ensure smooth and safe braking – with minimal operator effort.*

Electrical and control systems

- **Integrated Presence System (IPS)** *provides parking brake alarm, seat belt, warning light and hydraulic and interlock system for added safety.*
- **EngineProtect as standard** *continuously monitors and regulates RPM levels - reducing power output when vital fluids are low to reduce risk of damage.*

Operator compartment and controls

- **Full-suspension vinyl seat** *offers complete lumbar support – keeping operators comfortable through the longest shifts.*
- **Premium LED/LCD information panel** *keeps operators aware of issues affecting performance – from fuel levels to fluid temperatures – encouraging good maintenance.*

Other features

- **Low-noise design** *features rubber-mounted components, fully insulated steel engine hood, helical gears and enclosed wheel arches for maximum operator comfort.*
- **500-hour service interval** *and long component life reduces downtime and its associated costs.*
- **RapidAccess features** *include quick-release floor and steel side panels – no tools required – for faster daily inspections.*

Options

- **Intuitive fingertip controls**
- **Full suspension cloth seat**
- **Cabin package**



when reliability is everything

Like any product bearing the Mitsubishi name, our materials handling equipment benefits from the huge resources and cutting-edge technology of one of the world's largest corporations. So when we promise you **quality, reliability** and **value for money**, you know it's a guarantee we have the power to deliver.

Every model in our comprehensive, award-winning range of forklift trucks and warehouse equipment is built to a high specification and is designed to keep on working for you... day after day... year after year... whatever the job... whatever the conditions.

To ensure your truck stays in constant productive action, we have a network of local dealers – hand-picked for their commitment to customer care... and backed up by the Mitsubishi Forklift Trucks organisation. No matter where you are, we have a dealer close by – ready and willing to meet your needs.

That friendly local service covers everything from identifying the perfect model and configuration for your application to providing competitive, flexible finance and maintenance packages, unbeatable warranties, long and short term hire, and highly responsive field service and repairs... as well as the industry's quickest and most reliable parts supply.

Only Mitsubishi can give you this combination of global engineering excellence and outstanding local support... only Mitsubishi offers you such a quality product at such an affordable price... and only Mitsubishi places reliability as high as you do in its priorities. Contact your local dealer now and see what Mitsubishi can do for you.

You can find your nearest dealer at www.mitforklift.com

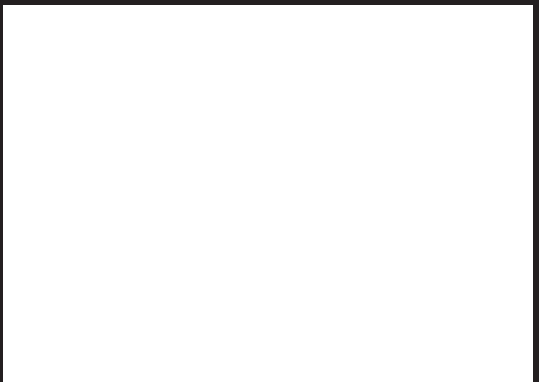

CESM1582 (06/14)
© 2014 MCFE
Printed in The Netherlands

mitforklift@mcf.nl www.mitforklift.com

NOTE: Performance specifications may vary depending on standard manufacturing tolerances, vehicle condition, types of tyres, floor or surface conditions, applications or operating environment. Trucks may be shown with non-standard options. Specific performance requirements and locally available configurations should be discussed with your distributor of Mitsubishi forklift trucks. Mitsubishi follows a policy of continual product improvement. For this reason, some materials, options and specifications could change without notice.